

INSTRUCTIONS

1. Loosen the lug nuts on both rear wheels and lift the vehicle so that there is no weight on the rear wheels. Raise the vehicle with a lift or jack stands and add wheel chocks for safety. Refer to your owner's manual to locate the jack stand's mounting locations for your specific vehicle.
2. Remove both the rear wheels and lug nuts and set aside.



3. Remove the top radius rods first by removing the top nuts and bolt on both ends of the radius rods. To do this, remove the chassis side radius rod bolt with nut and the radius rod hub side nut. Please see the attached image showing location of the bolt.



4. Once the radius rod is removed, adjust the length of the PM Off-Road radius rods heim joints. To do this, place two bolts through the OEM radius rods and loosen or tighten the heim joints on the PM radius rods. Adjust the heim joints so that there is an **equal number of threads exposed** on each side of the radius rods. Depending on your UTV model, tightening the jam nut may be easier before installing on your vehicle.



Note: Ensure to use the correct PM Off-Road radius rods when replacing the OEM rods. Please refer to the part number and description engraved on the radius rods and refer to this installation sheet. Use thread locker on all non-nylon hardware and torque to OEM specification. Please refer to your vehicle's owner's manual for exact torque specification.

PERFORMANCE MACHINE LIMITED WARRANTY INFORMATION

Performance Machine warrants to the original purchaser that the parts to be free of manufacturing defects in materials and workmanship for a period of (1) year from the date of purchase. In the event warranty service is required, you must call Performance Machine immediately with a description of the problem.

If it is deemed necessary for Performance Machine to make an evaluation to determine whether the part is defective, a return authorization number will be given by Performance Machine. The parts must be packaged properly so as to not cause further damage and returned prepaid to Performance Machine with a copy of the original invoice of purchase and a detailed letter outlining the nature of the problem. If after the evaluation by Performance Machine the part was found defective it will be repaired or replaced at no cost to you. If we replace it, we may replace it with a reconditioned one of the same design.

Performance Machine shall not be held liable for any consequential damage resulting from the failure of a Performance Machine part.

Performance Machine shall have no obligation if a part becomes defective as a result of improper installation or abuse.

FOR QUESTIONS PERTAINING TO THE INSTALLATION OF THIS PRODUCT, PLEASE CONTACT OUR TECHNICAL DEPARTMENT AT 1-800-479-4037

IMPORTANT NOTICE

Before installing, read through these instructions completely; this will familiarize you with the way in which parts fit together and the tools needed to complete the job.

This product involves alterations to your UTV and may void your factory warranty. PM STRONGLY recommends this installation be done by an experienced UTV mechanic.

DISCLAIMER

These Performance Machine parts are designed for high performance UTV applications and are intended for the very experienced rider only. The installation of these Performance Machine parts may adversely effect or void your factory warranty.



INSTRUCTIONS CONTINUED

5. Ensure that the stainless-steel misalignment spacers are in place at each end of the heim. Install the PM Off-Road Radius Rod into the hub side stud and reuse the existing washer and nut. On the opposite side, attach the other end of the heim joint using the chassis side bolt and nut.

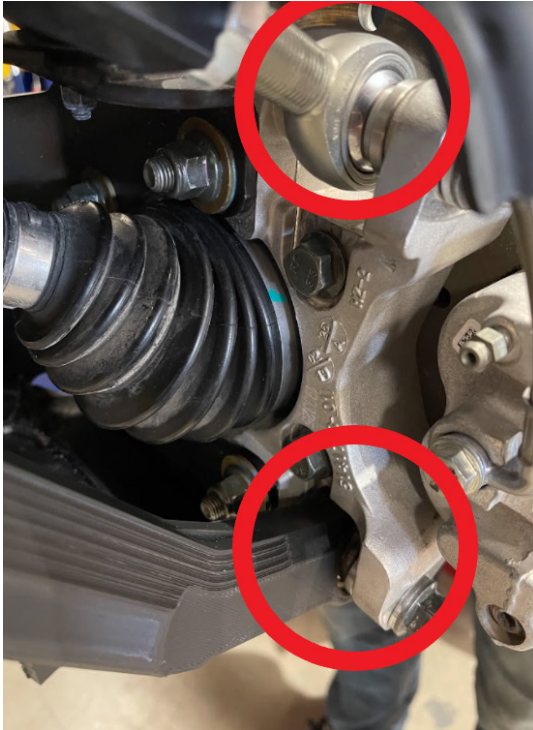

NOTE: Ensure that side of the radius rod with the part number engraving is toward the trailing arm side.

6. Repeat Step 4 and 5 for the remaining PM Off-Road Radius Rods and install the radius rods one at a time starting from the top radius rods to the bottom radius rods.

7. Once all radius rods are placed in the correct location, torque all the bolts to the manufacturers specifications as specified in the vehicle's owner's manual.

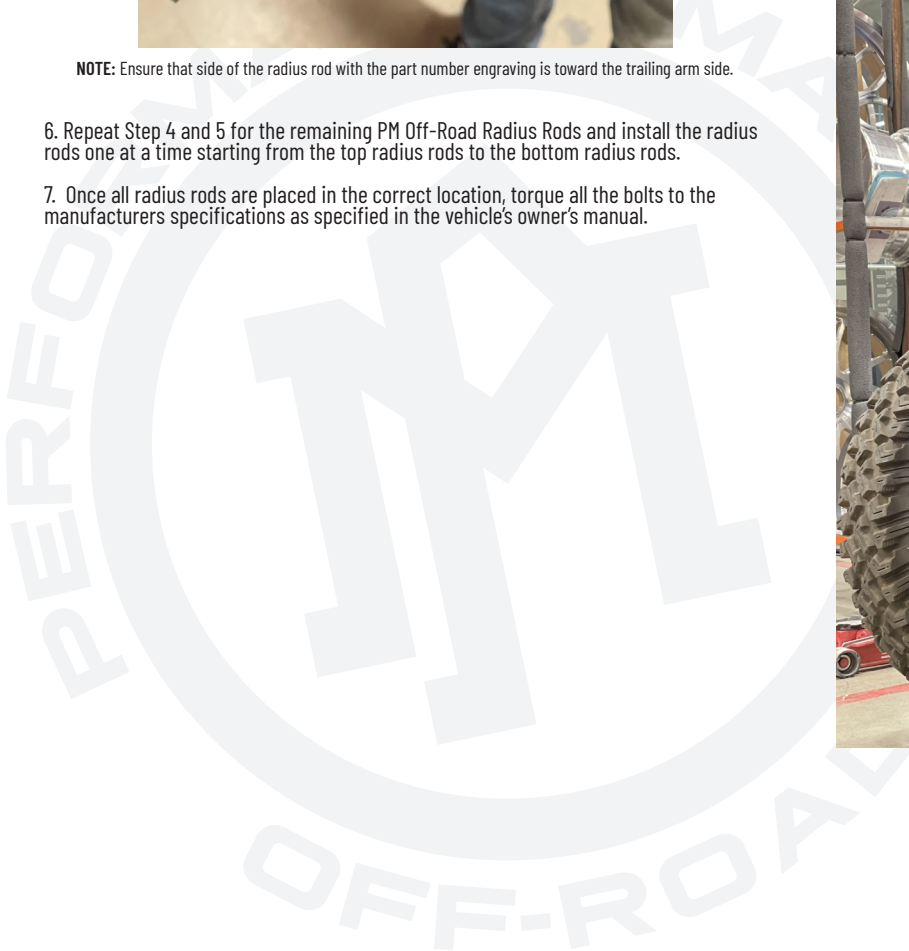



Top Radius Rod

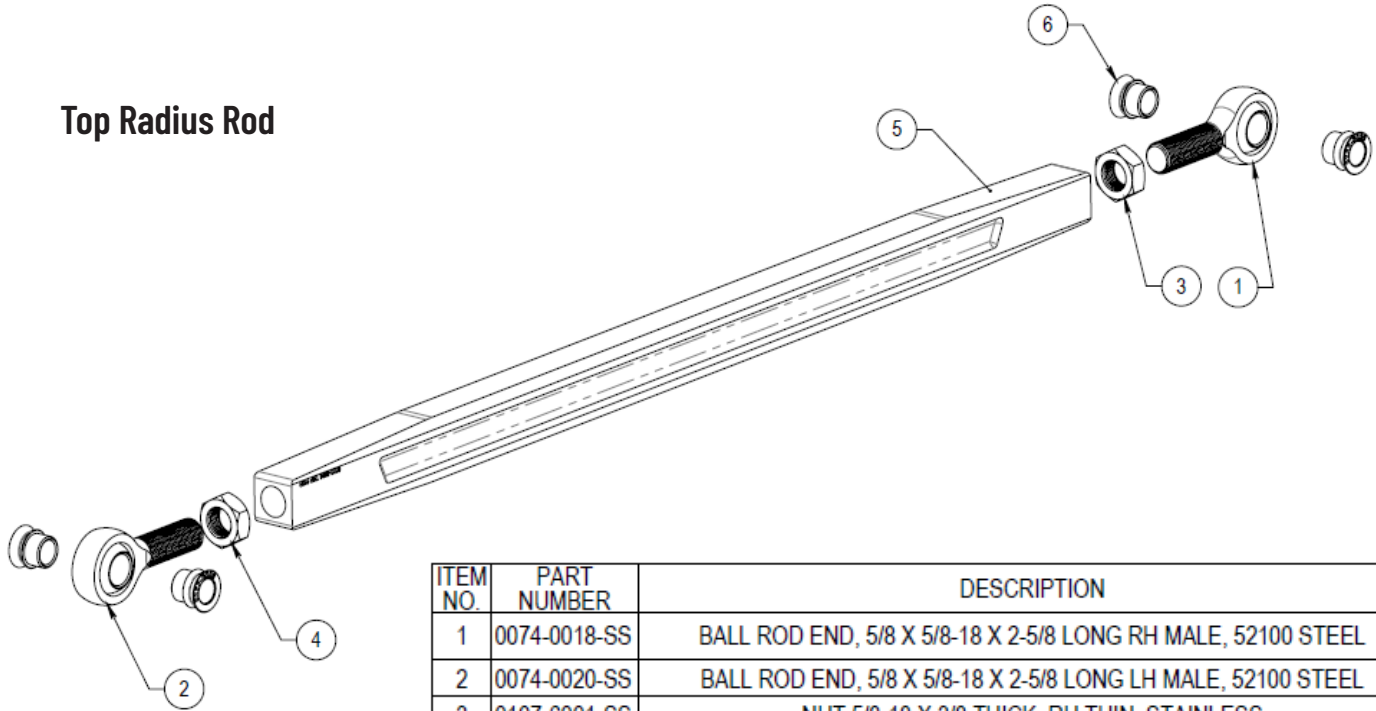

ITEM NO.	PART NUMBER	DESCRIPTION	QTY.
1	0074-0018-SS	BALL ROD END, 5/8 X 5/8-18 X 2-5/8 LONG RH MALE, 52100 STEEL	1
2	0074-0020-SS	BALL ROD END, 5/8 X 5/8-18 X 2-5/8 LONG LH MALE, 52100 STEEL	1
3	0107-6001-SS	NUT 5/8-18 X 3/8 THICK, RH THIN, STAINLESS	1
4	0107-6002-SS	NUT 5/8-18 X 3/8 THICK, LH THIN, STAINLESS	1
5	0222-0004	TOP RADIUS ROD, UTV HIGH CLEARANCE RADIUS ROD, RAZOR TURBO	1
6	0222-0009	MISALIGN SPACER HEIM JOINT, UTV RADIUS ROD, RAZOR TURBO	4

Bottom Radius Rod

LEFT

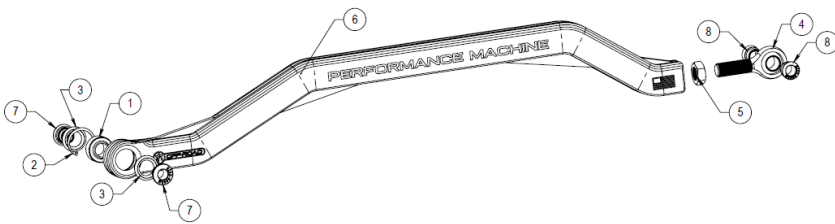

RIGHT

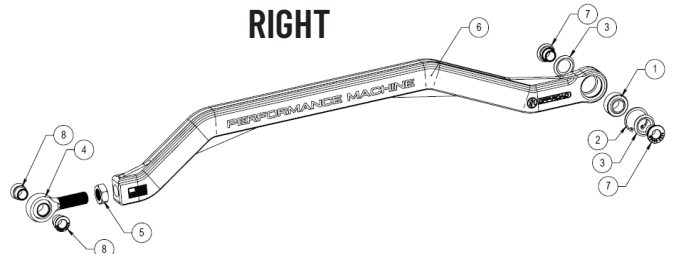

ITEM NO.	PART NUMBER	DESCRIPTION	QTY.
1	0071-6315	SPHERICAL BEARING 1-3/16 OD X 5/8 ID X 5/8 WIDE, 52100 STEEL	1
2	0072-0041-ZN	SNAP RING 1-3/16 INTERNAL, ZINC PLATED	1
3	0073-0107	O-RING .725 ID X 1.145 OD X .210, DASH 314 BUNA-N, 9452K387	2
4	0074-0018-SS	BALL ROD END, 5/8 X 5/8-18 X 2-5/8 LONG RH MALE, 52100 STEEL	1
5	0107-6001-SS	NUT 5/8-18 X 3/8 THICK, RH THIN, STAINLESS	1
6	0222-0005	BOTTOM RADIUS ROD LT, UTV HIGH CLEARANCE RADIUS ROD, RAZOR TURBO	1
7	0222-0008M	MISALIGN SPACER SPHERICAL BEARING, RADIUS ROD, RAZOR TURBO	2
8	0222-0009M	MISALIGN SPACER HEIM JOINT, UTV RADIUS ROD, RAZOR TURBO	2

ITEM NO.	PART NUMBER	DESCRIPTION	QTY.
1	0071-6315	SPHERICAL BEARING 1-3/16 OD X 5/8 ID X 5/8 WIDE, 52100 STEEL	1
2	0072-0041-ZN	SNAP RING 1-3/16 INTERNAL, ZINC PLATED	1
3	0073-0107	O-RING .725 ID X 1.145 OD X .210, DASH 314 BUNA-N, 9452K387	2
4	0074-0018-SS	BALL ROD END, 5/8 X 5/8-18 X 2-5/8 LONG RH MALE, 52100 STEEL	1
5	0107-6001-SS	NUT 5/8-18 X 3/8 THICK, RH THIN, STAINLESS	1
6	0222-0022	BOTTOM RADIUS ROD RT, UTV HIGH CLEARANCE RADIUS ROD, RAZOR TURBO	1
7	0222-0008M	MISALIGN SPACER SPHERICAL BEARING, RADIUS ROD, RAZOR TURBO	2
8	0222-0009M	MISALIGN SPACER HEIM JOINT, UTV RADIUS ROD, RAZOR TURBO	2